

Genesis Imaging Standoff Fixing Hanging Guide

1. Turn your work facedown, protecting the front of your work. Measure the distance between the centers of the standoff fixings. This will be the distance of the screws that will hold your work onto the wall.

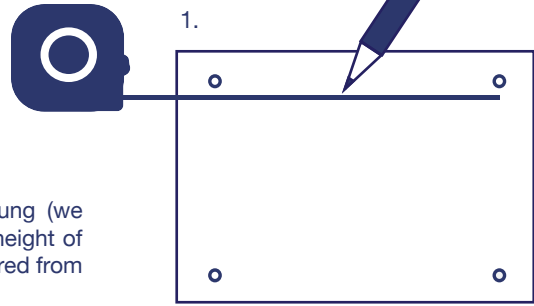

2. Determine the height at which your work will be hung (we recommend for standalone pieces a museum-standard height of 156cm to the center of the image). This should be measured from the floor upwards.

2.

3. Measure the centre of the back of your work (bottom to top - 3.1) and the distance between this measurement and that of the centre of your standoff fixings (3.2). This will inform the height at which you will be placing your screws, nails or hooks. If you are working at a height of 156cm and your standoff fixings are 10cm higher than the centre of your work, this will be a drilling height of 166cm.

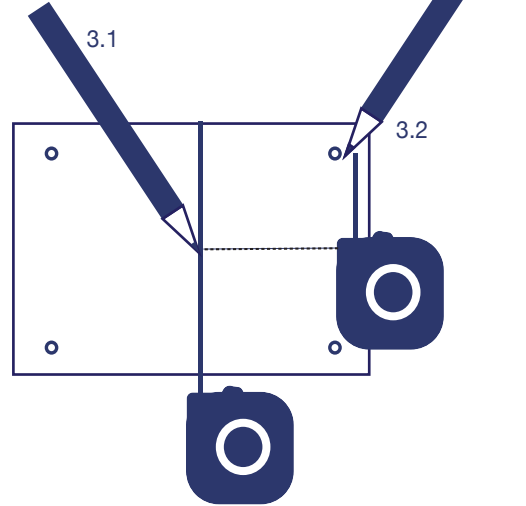

4. Mark your first measurement on the wall (always double-check this – it's easier to re-mark your wall than it is to re-drill a hole).

5. Place a subsequent mark the distance between the two standoff fixings (your measurement in the first step).



6. Check the measurements you have put on the wall with a spirit level.

7. Unscrew your fixings. Your screw will go through fig. 2 and into the wall before fig. 1 is re-screwed into this (through the work).

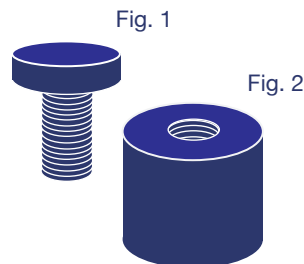

7.

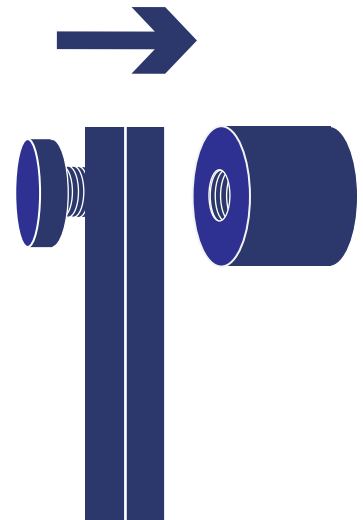

8. Depending on the surface and composition of your wall, the size and weight of your final piece, you may need to use heavyweight raw-plugs. If in doubt, please consult a building professional.



The highest quality services to transform your work into museum-quality showpieces.